

D-Link Quick Installation Guide

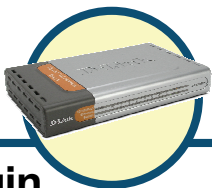

DES-1008F

10/100M Fast Ethernet Switch

Before Your Begin

This Quick Installation Guide gives step-by-step instructions for setting up the D-Link DES-1008F 10/100M Fast Ethernet Switch. The model you have purchased may appear slightly different from those shown in the illustrations.

Check Your Package Contents

These are the items included with your DES-1008F purchase:



- **DES-1008F 10/100M Fast Ethernet Switch**



- **Quick Installation Guide**



- **Power Adapter**



Using a power supply with a different voltage rating will damage and void the warranty for this product.

If any of the above items are missing, please contact your reseller.

1

Setup The DES-1008F 10/100M Fast Ethernet Switch

The setup of the Switch can be performed using the following steps:

- A. Install the DES-1008F in a fairly cool and dry place. See Technical Specification for the acceptable operation temperature and humidity ranges.
- B. Install the Switch in a site free from strong electromagnetic source, vibration, dust, and direct sunlight.
- C. Leave at least 10cm of space at the left and right hand side of the Switch for ventilation.
- D. Visually inspect the DC power jack and make sure that it is fully secured to the power adapter.



Do not stack any device on the Switch.

2

Mounting the Switch on a Wall

The DES-1008F can also be mounted on a wall. Two mounting slots are provided on the bottom of the switch for this purpose. Please make sure that the front panel is exposed in order to view the LEDs. Please refer to the illustration below:

- A. Mounting on a cement wall
 1. Mount the Nylon screw anchors into a cement wall.
 2. Drive the T3 x 15L screws into the Nylon screw anchors.
 3. Hook the mounting holes of the switch back on the screws; you have completed the wall-mount.
- B. Mounting on a wood wall
 1. Drive the T3 x 15 L screws into the wood wall.
 2. Hook the mounting holes of the switch back on the screws; you have completed the wall-mount.

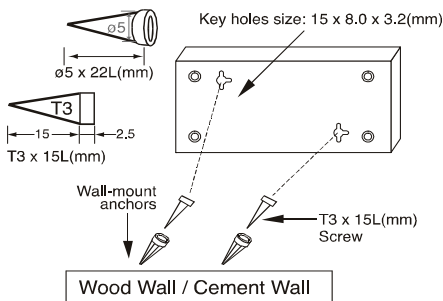

(1) 3/4 inch minimum
for wood wall

(2) 3 inch minimum
for cement wall.

3

Connecting The DES-1008F To Your Network

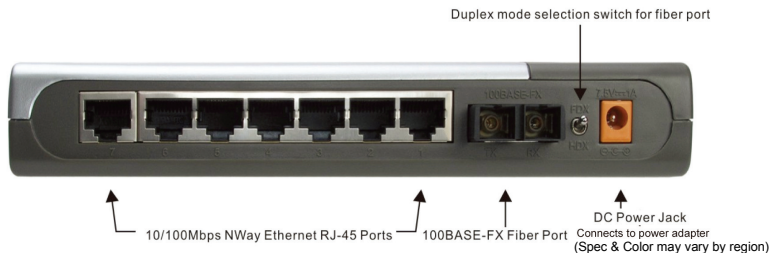

DES-1008F

DC Power Jack: Power is supplied through an external AC power adapter. Since the switch does not include a power switch, plugging its power adapter into a power outlet will immediately power it on.

Auto-MDI-X Function ports: Use these jacks (port1 ~ port-7) for DES-1008F to connect stations to the hub. An Auto-MDI-X function will automatically detect if a crossover is required and make the swap of TX pair and Rx pair internally. With this function, straight-through cable can be used for any connection. MDI to MDI-X connection rule is not necessary anymore. In the switches, all TX ports are equipped with this function. You can use just straight-through type cables for all your connections.

100BASE-FX Fiber Port: The DES-1008F Fiber port supports a 100BASE-FX Duplex SC connector for a 1310 nm Multi-mode fiber link of up to 2 km.

Duplex Mode Switch: The switch is to select the operation mode either to run in full or half duplex mode for 100BASE-FX. When turning the switch to FDX, the fiber port will run at full duplex or turn to HDX, the fiber will run at half duplex.

4

LED Indicators

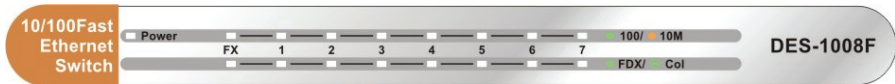

Power

This LED indicator lights green when the switch is receiving power, otherwise, it is off.

FDX/Col (Full-Duplex/Collision)

This LED indicator lights green when a respective port is in full duplex (FDX) mode. Otherwise, it is blinking when collisions are occurring on the respective port.

100M LINK/ACT(*green*), 10M LINK/ACT(*amber*)

This LED indicator lights green when the port is connected to a 100Mbps Fast Ethernet station, if the indicator blinking green will be transmission or received data on the 100Mbps network. Otherwise, if the indicator lights amber when the port is connected to a 10Mbps Ethernet station, if the indicator blinking amber will be transmission or received data on the 10Mbps network.

Technical Support

You can find software updates and user documentation on the D-Link website.

Tech Support for customers in

Australia:

Tel: 1300-766-868
24/7 Technical Support
Web: <http://www.dlink.com.au>
E-mail: support@dlink.com.au

India:

Tel: 1800-233-0000 (MTNL & BSNL Toll Free)
+91-832-2885700 (GSM, CDMS & Others)
Web: www.dlink.co.in
E-Mail: helpdesk@dlink.co.in
techsupport@dlink.co.in

Indonesia, Malaysia, Singapore and Thailand:

Tel: +62-21-5731610 (Indonesia)
Tel: 1800-882-880 (Malaysia)
Tel: +65 6501 4200 (Singapore)
Tel: +66-2-719-8978/9 (Thailand)
24/7, for English Support only
Web: <http://www.dlink.com.sg/support/>
E-mail: support@dlink.com.sg

Korea:

Tel: +82-2-2028-1815
Monday to Friday 9:00am to 6:00pm
Web: <http://www.d-link.co.kr>
E-mail: arthur@d-link.co.kr

New Zealand:

Tel: 0800-900-900
24/7 Technical Support
Web: <http://www.dlink.co.nz>
E-mail: support@dlink.co.nz

D-Link®
Building Networks for People

Technical Support

You can find software updates and user documentation on the D-Link website.

Tech Support for customers in

Egypt:

Tel: +202-2919035, +202-2919047
Sunday to Thursday 9:00am to 5:00pm
Web: <http://support.dlink-me.com>
E-mail: support.eg@dlink-me.com

Iran:

Tel: +98-21-88880918,19
Saturday to Thursday 9:00am to 5:00pm
Web: <http://support.dlink-me.com>
E-mail: support.ir@dlink-me.com
support@dlink.ir

Israel:

Magshimim 20, Petach Tikva 49348
Main Tel: 972-3-9215173
Customer Support Tel: 972-3-9212886
Web: www.dlink.co.il

Pakistan:

Tel: +92-21-4548158
+92-21-4548310
Monday to Friday 10:00am to 6:00pm
Web: <http://support.dlink-me.com>
E-mail: zkashif@dlink-me.com

South Africa and Sub Sahara Region:

Tel: +27-12-665-2165
08600 DLINK (for South Africa only)
Monday to Friday 8:30am to 9:00pm South Africa Time
Web: <http://www.d-link.co.za>
E-mail: support@d-link.co.za

Turkey:

Tel: +90-212-2895659
Monday to Friday 9:00am to 6:00pm
Web: <http://www.dlink.com.tr>
E-mail: turkiye@dlink-me.com

U.A.E and North Africa:

Tel: +971-4-4278127 (U.A.E)
Sunday to Thursday 9.00AM to 6.00PM GMT+4
Web: <http://www.dlink-me.com>
E-mail: support.me@dlink-me.com

Saudi ARABIA (KSA):

Tel: +966 01 217 0008
Fax: +966 01 217 0009
Saturday to Wednesday 9.30AM to 6.30PM
Thursdays 9.30AM to 2.00 PM
E-mail: Support.sa@dlink-me.com

D-Link[®]
Building Networks for People

Техническая поддержка

Обновления программного обеспечения и документация доступны на Интернет-сайте D-Link.

D-Link предоставляет бесплатную поддержку для клиентов в течение гарантийного срока.

Клиенты могут обратиться в группу технической поддержки D-Link по телефону или через Интернет.

Техническая поддержка D-Link:

+7(495) 744-00-99

Техническая поддержка через Интернет

<http://www.dlink.ru>

e-mail: support@dlink.ru

D-Link®
Building Networks for People

SOPORTE TÉCNICO

Usted puede encontrar actualizaciones de softwares o firmwares y documentación para usuarios a través de nuestro sitio www.dlinkla.com

SOPORTE TÉCNICO PARA USUARIOS EN LATINO AMERICA

Soporte técnico a través de los siguientes teléfonos de D-Link

PAIS	NUMERO	HORARIO
Argentina	0800 - 12235465	Lunes a Viernes 08:00am a 21:00pm
Chile	800 - 835465 ó (02) 5941520	Lunes a Viernes 08:00am a 21:00pm
Colombia	01800 - 9525465	Lunes a Viernes 06:00am a 19:00pm
Costa Rica	0800 - 0521478	Lunes a Viernes 05:00am a 18:00pm
Ecuador	1800 - 035465	Lunes a Viernes 06:00am a 19:00pm
El Salvador	800 - 6335	Lunes a Viernes 05:00am a 18:00pm
Guatemala	1800 - 8350255	Lunes a Viernes 05:00am a 18:00pm
México	01800 - 1233201	Lunes a Viernes 06:00am a 19:00pm
Panamá	011 008000525465	Lunes a Viernes 05:00am a 18:00pm
Perú	0800 - 00968	Lunes a Viernes 06:00am a 19:00pm
Venezuela	0800 - 1005767	Lunes a Viernes 06:30am a 19:30pm

Soporte Técnico de D-Link a través de Internet

www.dlinkla.com

e-mail: suporte@dlinkla.com & consultas@dlinkla.com

D-Link®
Building Networks for People

Suporte Técnico

Você pode encontrar atualizações de software e documentação de usuário no site da D-Link Brasil.

A D-Link fornece suporte técnico gratuito para clientes no Brasil durante o período de vigência da garantia deste produto.

Suporte Técnico para clientes no Brasil:

Website para suporte: www.dlink.com.br/suporte
e-mail: suporte@dlink.com.br

Telefones para contato:

Clientes de São Paulo: 2755 6950
Clientes das demais regiões: 0800 70 24 104
Segunda à Sexta-feira, das 9:00h às 21:00h
Sábado, das 8:00h às 15:00h

D-Link[®]
Building Networks for People

D-Link 友訊科技 台灣分公司 技術支援資訊

如果您還有任何本使用手冊無法協助您解決的產品相關問題，台灣地區用戶可以透過我們的網站、電子郵件或電話等方式與 D-Link 台灣地區技術支援工程師聯絡。

D-Link 免付費技術諮詢專線

0800-002-615

服務時間：週一至週五，早上 9:00 到晚上 9:00
(不含周六、日及國定假日)

網 站：<http://www.dlink.com.tw>

電子郵件：dssqa_service@dlink.com.tw

如果您是台灣地區以外的用戶，請參考 D-Link 網站 全球各地分公司的聯絡資訊以取得相關支援服務。

產品保固期限、台灣區維修據點查詢，請參考以下網頁說明：

<http://www.dlink.com.tw>

產品維修：

使用者可直接送至全省聯強直營維修站或請洽您的原購買經銷商。

D-Link®
Building Networks for People

Dukungan Teknis

Update perangkat lunak dan dokumentasi pengguna dapat diperoleh pada situs web D-Link.

Dukungan Teknis untuk pelanggan:

Dukungan Teknis D-Link melalui telepon:

Tel: +62-21-5731610

Dukungan Teknis D-Link melalui Internet:

Email : support@dlink.co.id

Website : <http://support.dlink.co.id>

D-Link[®]
Building Networks for People

D-Link®



RECYCLABLE

Ver.2.00 (WW)

2009/9/24

6DES1008FQM3G